

Zambrów, February 18, 2025

REQUEST FOR QUOTATION NO. 02/KPO/2025

In connection with the implementation of the project titled „ROBOTYZACJA I CYFRYZACJA KLUCZOWYCH PROCESÓW FIRMY JAKO ODPOWIEDŹ NA WYZWANIA FIRMY PO COVID-19,

implemented under **KRAJOWY PLAN ODBUDOWY I ZWIĘKSZENIA ODPORNOŚCI**

Komponent A „Odporność i konkurencyjność gospodarki”

Reforma: A 2.1. Przyspieszenie procesów robotyzacji i cyfryzacji i innowacji

Inwestycja: A 2.1.1. Inwestycje wspierające robotyzację i cyfryzację w przedsiębiorstwach

we invite you to submit an Offer.

1. Ordering Party:

Balton Sp. z o.o.
Strzelnicza 3
18-300 Zambrów
NIP: 5360015638

2. Procurement Procedure

2.1. This procedure is conducted in accordance with the rules specified in the annex to *REGULAMIN WYBORU PRZEDSIĘWZIĘĆ DO OBJĘCIA WSPARCIEM Z PLANU ROZWOJOWEGO W TRYBIE KONKURSOWYM FINANSOWANE W RAMACH KRAJOWEGO PLANU ODBUDOWY I ZWIĘKSZENIA ODPORNOŚCI*, tj. Załącznik nr 6 Zasada Konkurencyjności, the Principle of Competitiveness, developed by Ministerstwo Aktywów Państwowych, which is part of the competition documentation available at <https://www.gov.pl/web/aktywa-panstwowe/inwestycje-wspierajace-robotyzacje-i-cyfryzacje-w-przedsiębiorstwach--tryb-konkursowy>.

2.2. The Ordering Party is not obliged to apply the *Ustawa z dnia 11 września 2019 r. - Prawo zamówień publicznych* (tekst jedn.: Dz. U. 2019 poz. 2019.).

2.3. The provisions of the *Ustawa z dnia 23 kwietnia 1964 r. Kodeks cywilny (Dz.U. z 2022 r. poz. 1360, z późn. zm.)* apply to the actions taken by the Ordering Party, Contractors, and participants in the procurement procedure and agreements related to procurement matters.

2.4. The Ordering Party reserves the right to modify the Request for Quotation at any stage of the procurement procedure and to cancel the procedure at any time without stating a reason. In the event of cancellation, Contractors shall not be entitled to any claims against the Ordering Party.

2.5. The result of the procedure will be published in the same manner as this Request for Quotation.

3. Type of Order

- Supply/~~Services/Construction works~~

4. Name and Code Defined in Wspólny Słownik Zamówień (CPV):

- Plastic processing machines (42994200-2);
- Casting molds (43415000-5).

5. Subject of the Order

5.1. The subject of the order consists of 4 parts, with no possibility of submitting offers for individual parts due to the need to maintain compatibility:

- Part 1 – Liquid Silicone Rubber (LSR) Injection Molding Machine;
- Part 2 – Mold for YCONV bushing production;
- Part 3 – Mold for 20 Sh silicone valve production;
- Part 4 – Mold for 40 Sh silicone valve production.

5.2. A detailed description of the subject of the order is included in Attachment No. 4 to this Request for Quotation.

6. Conditions for Participation in the Procedure

6.1. Contractors who meet the following conditions may apply for the order:

- Possess the necessary authorizations to conduct specified activities or actions if required by law;
- Have knowledge and experience in properly executing the order;
- Have appropriate technical potential and personnel capable of executing the order;
- Are in a financial and economic situation that allows them to fulfill the order within the specified timeframe;
- Are not personally or financially related to the Ordering Party.

6.2. To confirm compliance with the participation conditions, the Contractor must submit:

- An offer according to the template in Attachment No. 1 to this Request for Quotation;
- A statement regarding the absence of ties with the Ordering Party, as per the template in Attachment No. 2;
- A statement confirming compliance with the participation conditions, as per the template in Attachment No. 3.

6.3. Failure to meet any of the participation conditions will result in exclusion from the procedure. Excluded offers will be rejected.

7. Method of Price Calculation

7.1. The Contractor provides a price for the execution of the subject of the order according to the Offer Form template in Attachment No. 1.

7.2. The offered price must cover the entire subject of the order, including all costs specified in this Request for Quotation, annexes, and any additional information for Contractors (lump-sum remuneration).

7.3. The price in the Offer Form is final, non-negotiable, and covers all obligations of the Contractor towards the Ordering Party related to executing the order.

7.4. The price should be expressed in PLN or another currency. If stated in another currency, it will be converted to PLN based on the NBP exchange rate on the publication date of this Request for Quotation.

8. Criteria for evaluating offers, including information on point or percentage weights assigned to individual evaluation criteria and a description of the scoring method for meeting a given evaluation criterion.

8.1. Evaluation criteria:

a) Net price – 100 points (100%)

The point value of the price will be calculated using the formula:

$(C_{min} : C_n) \times 100$, where:

C_{min} - the lowest net total price among non-rejected offers

C_n - the net total price of the evaluated offer

The offer can receive a maximum of 100 points (1% = 1 point).

Results will be rounded to two decimal places.

8.2. The total evaluation will include the sum of points obtained by the offer in the criteria specified in point 8.1. Points will be counted to two decimal places using common rounding rules.

8.3. The Ordering Party will award the contract to the Contractor whose offer meets all the requirements of the Request for Quotation and is evaluated as the most advantageous based on the established evaluation criteria, obtaining the highest number of points.

8.4. If the Ordering Party cannot select the most advantageous offer because the submitted offers received the same number of points, the Ordering Party will ask the Contractors who submitted those offers to submit additional offers within a deadline set by the Ordering Party. Contractors submitting additional offers cannot offer prices higher than those initially submitted.

9. Method of Preparation and Submission of Offers

9.1. The offer must be submitted using the Offer Form (Attachment No. 1 to the Request for Quotation) along with the statements and documents specified in point 6.2 of this Request for Quotation, as well as documents confirming the right to sign the Offer in accordance with point 9.4, including the appropriate power of attorney in accordance with point 9.5 (if applicable).

9.2. The Contractor may submit only one offer.

9.3. The offer must be prepared in written form in Polish or English.

9.4. The offer must be signed by a person authorized to represent the Contractor, in accordance with the form of representation specified in the register or other document appropriate for the given organizational form of the Contractor, or by an authorized representative. To confirm that the person acting on behalf of the Contractor is authorized to represent them, the Ordering Party

requires the Contractor to submit an excerpt or information from the National Court Register, the Central Register and Information on Business Activity, or another relevant register.

9.5. The power of attorney of the person(s) signing the Offer to represent the Contractor, incur financial obligations on their behalf corresponding to the value of the Offer, and sign the Offer must directly result from the Contractor's registration documents. This means that if such power of attorney does not directly result from the document confirming the Contractor's legal status (an excerpt from the appropriate register or the central register and information on business activity), the Offer must include a power of attorney issued to the Contractor's representative by authorized persons.

9.6. The power of attorney to submit the offer must be submitted in the same form as the submitted offer.

9.7. A consortium offer, i.e., a joint offer submitted by several Contractors, must include a power of attorney. The power of attorney must specify which partner will represent the others before the Ordering Party and which proceedings the power of attorney concerns.

9.8. The offer may be submitted in paper form with a handwritten signature, in electronic form with a qualified electronic signature, or in electronic form with a trusted signature or personal signature. The submission of a scanned copy of the paper offer is also permitted.

9.9. Paper form offers must be delivered to the Ordering Party's headquarters in person or via mail/courier to the following address: Balton Sp. z o.o., Strzelnicza 3, 18-300 Zambrów, whereas other offers must be submitted to the following email address: zamowienia.zewnetrzne@balton.pl. The deadline for submission is March 21, 2025. The opening of offers will take place no later than three days after the submission deadline.

9.10. Any corrections to the Offer must be made in a legible manner, additionally dated, and initialed by the person signing the offer.

9.11. Offers that do not meet formal requirements or do not include the full scope of the subject of the order will be rejected.

9.12. The Contractor may modify or withdraw a submitted offer before the submission deadline. Both modification and withdrawal of the offer require the same form as the submitted offer.

9.13. The Ordering Party reserves the right to modify the request for quotation and the offer form in the event of errors in the request for quotation or the necessity of making additions. In such cases, the Ordering Party will:

- Inform about the modification in the manner appropriate for the publication of this request for quotation;
- Inform all bidders who have already submitted offers about the modification;
- If necessary, extend the submission deadline by the time needed to introduce changes to the offers submitted by bidders.

9.14. Bidders are entitled to submit questions or request clarifications regarding the content of this Request for Quotation. The Ordering Party is obliged to provide clarifications immediately, but no later than four days before the submission deadline, provided that the question was received no later than six days before the submission deadline. Questions should be sent to the email address: zamowienia.zewnetrzne@balton.pl.

10. Information on the possibility of submitting partial offers

10.1. The Ordering Party does not allow the submission of partial offers.

11. Information on planned supplementary orders

11.1. The Ordering Party does not allow the submission of supplementary offers.

12. Information on the possibility of submitting variant offers

12.1. The Ordering Party does not allow the submission of variant offers.

13. Bid bond

13.1. The Ordering Party does not require a bid bond.

14. Offer binding period

14.1. The Contractor is bound by the offer for 60 days from the deadline for submitting offers.

14.2. If the selection of the most advantageous offer does not take place before the offer binding period expires, the Ordering Party may, before the expiration of the offer binding period, request the Contractors to extend this period once for a specified period not exceeding 30 days.

14.3. The extension of the offer binding period, as mentioned above, requires the Contractor to submit a written statement of consent to extend the offer binding period.

14.4. If the Ordering Party requires a bid bond, the extension of the offer binding period, as mentioned above, must be accompanied by an extension of the validity period of the bid bond or, if this is not possible, by the submission of a new bid bond for the extended offer binding period.

15. Information on the formalities that should be completed after selecting an offer in order to conclude a public procurement contract.

15.1. A contract will be concluded with the Contractor whose offer has been selected as the most advantageous, in accordance with the content of the request for quotation and the submitted offer, taking into account in particular the essential terms of the contract and the conditions for changing the essential terms of the contract contained in point 17. The place and date of signing the contract will be specified by the Ordering Party.

15.2. The contract with the Contractor will be concluded in written form or electronic form (signed with a qualified electronic signature).

15.3. If the Ordering Party allows the submission of partial offers, the procurement procedure may result in the conclusion of a contract for part of the order.

15.4. If the Contractor whose offer was selected as the most advantageous withdraws from signing the contract, the Ordering Party may conclude a contract with the Contractor whose offer was the most advantageous among the remaining offers, without re-examining and evaluating the offers.

15.5. In the case of selecting the most advantageous offer submitted by Contractors jointly applying for the contract, before signing the contract, it is necessary to submit a cooperation agreement that will regulate the mutual cooperation of the Contractors. Contractors jointly applying for the contract are jointly and severally liable for the performance of the contract.

15.6. Persons representing the Contractor when signing the contract should have documents confirming their authorization to sign the contract, unless this authorization is evident from the documents attached to the offer.

16. Deadline and place of order execution

16.1. Order execution period: 180 calendar days from the date of signing the contract.

16.2. Place of order execution: Strzelnicza 3, Zambrów.

16.3. The order execution period is considered fulfilled upon signing the acceptance protocol.

17. Essential terms of the contract and conditions for changing essential terms of the contract

17.1. The essential terms of the contract are included in Attachment No. 5 to the Request for Quotation.

17.2. Changes to the essential terms of the concluded contract can only be made if:

- the possibility of change was foreseen in the contract;
- force majeure occurs – if the Ordering Party, acting with due diligence, could not foresee the changes, and their value does not exceed 50% of the order.

17.3. It is not possible to make significant changes to the provisions of the concluded contract compared to the content of the offer on the basis of which the Contractor was selected unless:

- 1) the changes were foreseen in the contract in the form of clear, precise, and unambiguous provisions specifying their scope and type as well as the conditions for introducing changes;
- 2) the changes concern the execution of additional supplies, services, or construction works from the existing Contractor, not covered by the basic order, provided that they have become necessary and all the following conditions are met:
 - a) changing the Contractor cannot be made for economic or technical reasons, particularly related to interchangeability or interoperability of equipment, services, or installations ordered under the basic contract,
 - b) changing the Contractor would cause significant inconvenience or a significant increase in costs for the Ordering Party,
 - c) the value of each subsequent change does not exceed 50% of the original contract value;
- 3) the change does not alter the nature of the contract, and all the following conditions are met:
 - a) the need to change the contract is caused by circumstances that the Ordering Party, acting with due diligence, could not foresee,
 - b) the value of the change does not exceed 50% of the original contract value;

- 4) the Contractor to whom the Ordering Party awarded the contract is replaced by a new Contractor:
 - a) based on contractual provisions,
 - b) as a result of merger, division, transformation, bankruptcy, restructuring, or acquisition of the existing Contractor or its enterprise, provided that the new Contractor meets the conditions for participation in the procurement procedure, is not subject to exclusion, and does not result in other significant contract changes,
 - c) as a result of the Ordering Party taking over the Contractor's obligations towards its subcontractors. In the case of a subcontractor change, the Ordering Party may conclude a contract with a new subcontractor without changing the order execution conditions, considering the payments already made for completed works;
- 5) the change does not alter the overall nature of the contract, and the total contract value is lower than the EU thresholds and is less than 10% of the original contract value for service or supply contracts or 15% for construction contracts.

18. Conditions for possible withdrawal from signing the contract.

18.1. The Ordering Party may withdraw from signing the contract if the offer amount exceeds the funds the Ordering Party intends to allocate for the execution of this order. The Ordering Party may also withdraw from signing the contract without stating a reason in case of changes in the circumstances of the entire Project implementation.

19. Scope of Personal Data Processing

19.1. The Bidder consents to the collection and processing of their personal data by the Ordering Party to the extent necessary for the implementation of this procurement procedure, in accordance with Regulation (EU) 2016/679 of the European Parliament and of the Council of 27 April 2016 on the protection of natural persons with regard to the processing of personal data and on the free movement of such data, and repealing Directive 95/46/EC (General Data Protection Regulation). The processing of entrusted personal data will comply with the GDPR and related national personal data protection regulations.

19.2. The Ordering Party declares that it is the data controller for the data referred to in this request for quotation.

19.3. The Ordering Party will process personal data to conduct the procurement procedure and fulfill a legal obligation based on Article 6(1)(c) of the GDPR.

19.4. Providing personal data is a condition for participating in this procedure and a legal requirement to fulfill obligations under the law. Failure to provide personal data prevents the Bidder from participating in the procurement procedure.

19.5. Data recipients may include, in particular, Intermediate Institutions, Managing Institutions, other state and EU institutions, as well as entities engaged by these institutions for audits, settlements, and project control, including the Tax Office, Bank, Legal Office, Polish Post, courier companies. Additionally, data may be transferred/shared with suppliers and subcontractors of services such as IT specialists, accounting firms, consulting companies – these entities process data only based on a contract and solely according to instructions.

19.6. The Bidder has the following rights:

- Under Article 15 of the GDPR, the right to access personal data concerning the Bidder;
- Under Article 16 of the GDPR, the right to rectify the Bidder's personal data;
- Under Article 18 of the GDPR, the right to request the data controller to restrict the processing of personal data, subject to the cases specified in Article 18(2) of the GDPR.

19.7. At any time, the Bidder has the right to lodge a complaint with the supervisory authority (GIODO or its legal successor - Prezes Urzędu Ochrony Danych Osobowych).

19.8. The processing period includes the period of fulfilling obligations, the limitation period for claims resulting from regulations, and the period of storing project documentation in accordance with the provisions of the project funding agreement.

19.9. If a contract or order is concluded between the Bidder and the Ordering Party, the data provided by the Bidder will be processed to execute such a contract or order and its settlement.

Attachments to the Request for Quotation

- Attachment No. 1 – Offer Form
- Attachment No. 2 – Declaration of No Personal or Capital Links with the Ordering Party
- Attachment No. 3 – Declaration of Compliance with Participation Conditions
- Attachment No. 4 – Detailed description of the subject of the order
- Attachment No. 5 – Essential Terms of the Contract

Attachment No. 1 to the Request for Quotation

OFFER FORM
(to Request for Quotation No. 02/KPO/2025)

.....
Contractor Name

.....
Contractor Address

.....
Contractor Tax ID (NIP)
.....

Contact Phone Number

.....
Contact Email Address

We hereby offer to execute the subject of the order in accordance with the detailed description specified in Attachment No. 4 to the Request for Quotation, as per the following breakdown:

subject of the order	Net Price	VAT	Gross Price	Currency
LSR (LIQUID SILICONE RUBBER) INJECTION MOULDING MACHINE				
Sleeve YCONV mould				
Haemostatis valve mould 20 Sh				
Haemostasis valve mould 40 Sh				
Total amount				

1. Order completion deadline: 180 calendar days counted from the date of signing the contract.
2. Offer validity period: 60 days from the offer submission date.

Attachments to the Offer Form:

- Attachment No. 2 to the Request for Quotation – Declaration of No Personal or Financial Links with the Ordering Party.

- Attachment No. 3 to the Request for Quotation – Declaration of Compliance with Participation Conditions.

(Location, Date)

*(Seal, Signatures of Authorized Persons
Representing the Contractor)*

Attachment No. 2 to the Request for Quotation

Declaration of No Personal or Capital Links with the Ordering Party
(to Request for Quotation No. 02/KPO/2025)

Acting on behalf of and in the name of _____, we declare that we have no personal or capital links with the Ordering Party.

Personal and capital links shall be understood as:

- 1) participation in a company as a partner in a civil law partnership or a partnership;
- 2) holding at least 10% of shares or stocks (unless a lower threshold results from legal regulations);
- 3) serving as a member of the supervisory or management body, proxy, or attorney;
- 4) being married, in a direct or collateral kinship relationship up to the second degree, or legally bound by adoption, guardianship, or custody, or cohabiting with the contractor, their legal representative, or members of the managing or supervisory bodies of the contractors applying for the order;
- 5) remaining in a legal or factual relationship with the contractor, which raises justified doubts about their impartiality or independence in connection with the procurement procedure.

(Location, Date)

(Seal, Signatures of Authorized Persons
Representing the Contractor)

Attachment No. 3 to the Request for Quotation

Declaration of Compliance with Participation Conditions
(to Request for Quotation No. 02/KPO/2025)

Acting on behalf of and in the name of _____, we declare that:

1. we are familiar with and accept the conditions for the execution of the order as specified in the request for quotation, and we do not raise any objections or comments in this regard;
2. we have the necessary authorizations to conduct specific business activities or perform specific actions, if required by law;
3. we possess the knowledge and experience necessary for the proper execution of the order;
4. we have the appropriate technical potential and personnel capable of executing the order;
5. we are in an economic and financial situation that allows us to execute the order within the specified timeframe;
6. we commit to signing the contract for the execution of this order at the place and time specified by the Ordering Party;
7. we consent to the collection and processing of our personal data by the Ordering Party to the extent necessary for the execution of this procurement procedure, in accordance with **Regulation (EU) 2016/679 of the European Parliament and of the Council of April 27, 2016**, on the protection of natural persons with regard to the processing of personal data and on the free movement of such data, repealing **Directive 95/46/EC** (hereinafter referred to as "GDPR" or "General Data Protection Regulation");
8. we declare that we are not subject to exclusion from the procedure under **Article 7, Section 1 of the Act of April 13, 2022, on special solutions for counteracting the support of aggression against Ukraine and ensuring national security** (Journal of Laws of 2022, item 835).

(Location, Date)

(Seal, Signatures of Authorized Persons
Representing the Contractor)

Attachment No. 4 to the Request for Quotation

Detailed description of the subject of the order
(to Request for Quotation No. 02/KPO/2025)

Part 1 – LSR (liquid silicone rubber) injection moulding machine

USER REQUIREMENTS SPECIFICATION

1) Introduction

Specification applies to process: LSR (liquid silicone rubber) injection moulding machine purchasing.

Usage: LSR parts producing, by injection molding.

Name of the process – liquid silicone injection.

2) Description of the item to which URS applies

Machine description:

Injection molding machine should consist an injection system in a horizontal configuration, clamping system, drive system, control system with touch panel, mechanical and pneumatic system, robot collecting ingots or parts.

3) Definition

LSR- liquid silicone rubber

4) User Requirements (URS)

URS includes:

- Design and environmental requirements - description of main functionalities in relation to design and environmental conditions, including e.g. key components, location, integration with IT infrastructure, etc.,
- Functional requirements – description of the functions in relation to in progress processes.
- Law requirements – reference to standards, regulations, guides, etc.,
- Other requirements, e.g. service requirements, documentation.

No	Description of the requirement
URS/1	Following documents should be provided with the machine: <ul style="list-style-type: none"> • Certificate - Declaration of Conformity • CE mark • Electric scheme • User manual – Polish/English • Spare parts list • Maintenance schedule • Health and Safety Instruction
URS/2	TDS delivered in Polish and English language, in paper and electronic version.
URS/3	Injection moulding machine must fulfill following conditions: <ul style="list-style-type: none"> • Power supply adapted to TN-C-S 400V 50Hz system • Pneumatic supply pressure less than 10 bar • Cooling water supply pressure less than 5 bar
URS/4	Dimensions of injection moulding machine should be in the range of: <ul style="list-style-type: none"> • height (with robot) - 2800 mm • width - 1200 mm • length - 2800 mm
URS/5	Machine should be based on an injection system in a horizontal configuration adapted to injection of liquid silicone LSR
URS/6	Machine should have min. 4 heating zones with system for controlling the temperature of injection mould
URS/7	Machine should have a theoretical injection volume of min. 5cm ³
URS/8	Machine external build should allow for easy maintenance of the cleanliness, which will be located in the ISO 8 class clean zone
URS/9	Injection and heating system should be made in a technology that allows processing of liquid LSR silicone
URS/10	Injection system should be equipped with a needle-closed nozzle
URS/11	Machine should be equipped with a feeding and mixing device for liquid silicone components
URS/12	With machine it's expected to deliver tool solution for production of haemostatis valve with a diameter of 8.2 mm and thicknesses: 1.45 mm and 1.4 mm; sleeve with dimensions attached; any form multiplicity, theoretical efficiency min. 5000 pcs. for 8 hours of work (1 shift)
URS/13	Machine maximum clamping force should be more than 50kN
URS/14	All machine movements should be controlled from a control equipped with digital settings and a graphical interface allowing for process observation.
URS/15	Software/hardware of controller should enable recording process data to IT systems.
URS/16	Machine should be able to send process data via the OPC-UA protocol
URS/17	Machine should have additional ports to connect with peripherals
URS/18	Machine must be covered by at least a 2-year manufacturer's warranty.
URS/19	Measurement tools must be supplied and calibrated with calibration documentation. Supplier needs to determine the frequency of recommended recalibrations.
URS/20	The supplier will train Balton employees in the proper operation and operation of the device.
URS/21	Machine acceptance based on the received terms, included in the FAT/SAT protocol.

Part 2 – Sleeve YCONV mould

USER REQUIREMENTS SPECIFICATION

1) Introduction

Specification includes requirement of purchasing for mould to produce YCONV sleeve from LSR material.

Name of process – injection.

Mould for YCONV sleeve production.

Place of use – room 17 (injection room) and 20 (raw material room) in Zambrów, Strzelnicza 3 Street.

2) Description

Mold for production of YCONV sleeve from LSR (Liquid Silicone Rubber) material.

3) User Requirements (URS)

URS includes:

- Design and environmental requirements - description of main functionalities in relation to design and environmental conditions, including e.g. key components, location, integration with IT infrastructure, etc.,
- Functional requirements – description of the functions in relation to in progress processes.
- Law requirements – reference to standards, regulations, guides, etc.,
- Other requirements, e.g. service requirements, documentation.

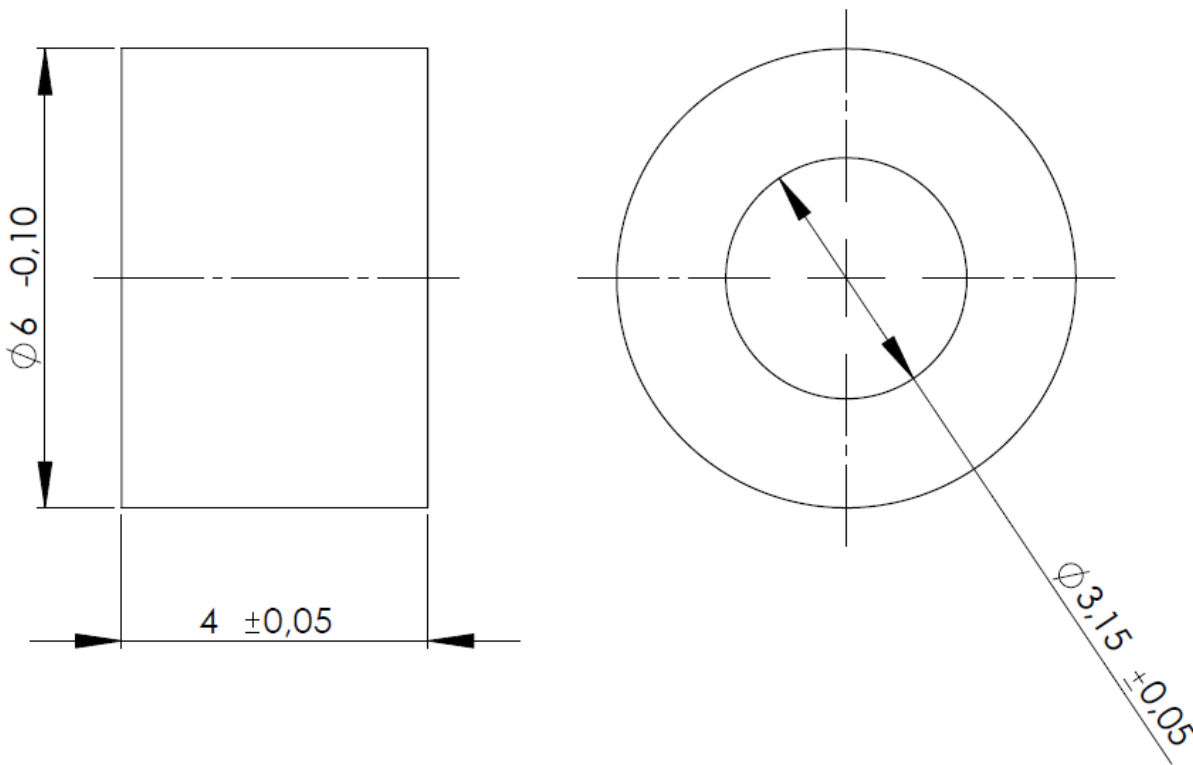
No	Description of the requirement
URS/1	Forming parts – made of 1.2083 50-52 HRC steel.
URS/2	<p>Detail received from mould should be consistent with attached technical drawing (below).</p> 
URS/3	Number of moulded details received from one cycle – min. 4 pcs.
URS/4	Moulded parts releasing with a pushing plate.
URS/5	Manufacturer is obliged to provide its documentation together with the mould, in digital form (m.in. current drawings of 2D and 3D forming parts).
URS/6	Mould should be delivered within 12 weeks from the payment of 50% of the order value.

Part 3 – Haemostatis valve mould 20 Sh

USER REQUIREMENTS SPECIFICATION

1) Introduction

Specification includes requirement of purchasing for mould to produce haemostatis valve (disc-shape) 20 Sh, made from LSR material.

Name of process – injection.

Mould for Haemostasis valve 20 Sh production.

Place of use – room 17 (injection room) and 20 (raw material room) in Zambrów, Strzelnicza 3 Street.

2) Description of the item to which URS applies

Mold for production of haemostatis valve 20 Sh from LSR (Liquid Silicone Rubber) material.

3) User Requirements (URS)

URS includes:

- Design and environmental requirements - description of main functionalities in relation to design and environmental conditions, including e.g. key components, location, integration with IT infrastructure, etc.,
- Functional requirements – description of the functions in relation to in progress processes.
- Law requirements – reference to standards, regulations, guides, etc.,
- Other requirements, e.g. service requirements, documentation.

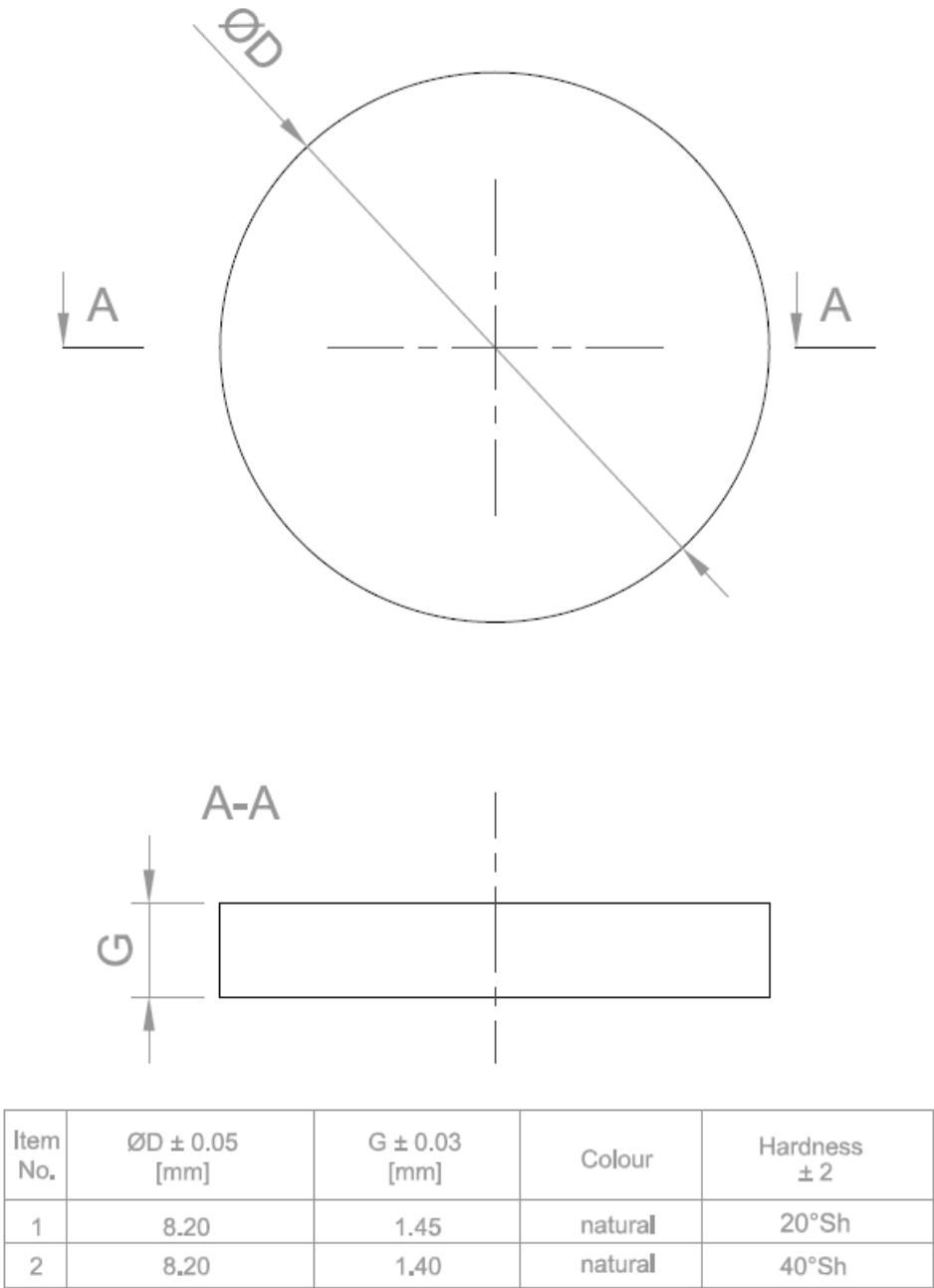
No	Description of the requirement															
URS/1	Forming parts – made of 1.2083 50-52 HRC steel.															
URS/2	<p>Detail received from mould should be consistent with attached technical drawing (below). (dimensions from the table – point 1).</p>  <table border="1" data-bbox="395 1556 1337 1736"> <thead> <tr> <th>Item No.</th> <th>$\varnothing D \pm 0.05$ [mm]</th> <th>$G \pm 0.03$ [mm]</th> <th>Colour</th> <th>Hardness ± 2</th> </tr> </thead> <tbody> <tr> <td>1</td> <td>8.20</td> <td>1.45</td> <td>natural</td> <td>20°Sh</td> </tr> <tr> <td>2</td> <td>8.20</td> <td>1.40</td> <td>natural</td> <td>40°Sh</td> </tr> </tbody> </table>	Item No.	$\varnothing D \pm 0.05$ [mm]	$G \pm 0.03$ [mm]	Colour	Hardness ± 2	1	8.20	1.45	natural	20°Sh	2	8.20	1.40	natural	40°Sh
Item No.	$\varnothing D \pm 0.05$ [mm]	$G \pm 0.03$ [mm]	Colour	Hardness ± 2												
1	8.20	1.45	natural	20°Sh												
2	8.20	1.40	natural	40°Sh												
URS/3	Number of moulded details received from one cycle – min. 4 pcs.															
URS/4	Moulded parts releasing with a pushing plate.															
URS/5	Manufacturer is obliged to provide its documentation together with the mould, in digital form (m.in. current drawings of 2D and 3D forming parts).															
URS/6	Mould should be delivered within 12 weeks from the payment of 50% of the order value.															

Part 4 – Haemostasis valve mould 40 Sh

USER REQUIREMENTS SPECIFICATION

1) Introduction

Specification includes requirement of purchasing for mould to produce haemostatis valve (disc-shape) 40 Sh, made from LSR material.

Name of process – injection.

Mould for Haemostasis valve 40 Sh production.

Place of use – room 17 (injection room) and 20 (raw material room) in Zambrów, Strzelnicza 3 Street.

2) Description of the item to which URS applies

Mold for production of haemostatis valve 40 Sh from LSR (Liquid Silicone Rubber) material.

3) User Requirements (URS)

URS includes:

- Design and environmental requirements - description of main functionalities in relation to design and environmental conditions, including e.g. key components, location, integration with IT infrastructure, etc.,
- Functional requirements – description of the functions in relation to in progress processes.
- Law requirements – reference to standards, regulations, guides, etc.,
- Other requirements, e.g. service requirements, documentation.

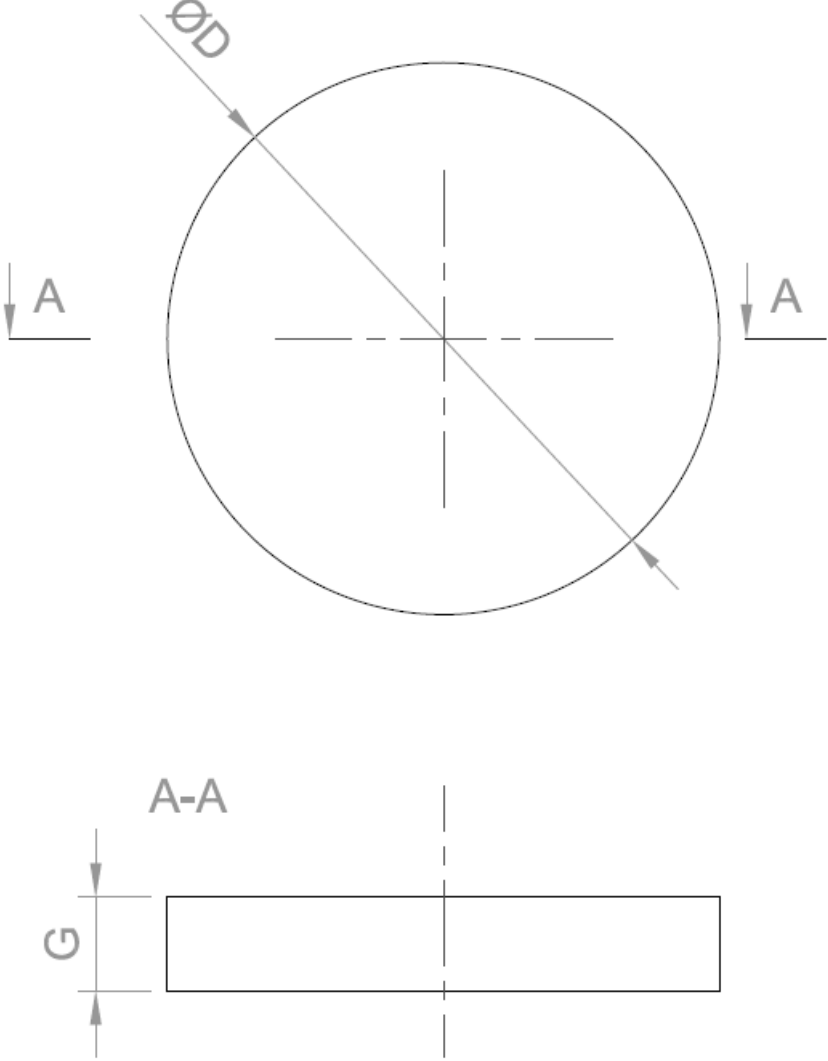

No	Description of the requirement															
URS/1	Forming parts – made of 1.2083 50-52 HRC steel.															
URS/2	<p>Detail received from mould should be consistent with attached technical drawing (below). (dimensions from the table – point 2).</p>  <table border="1" data-bbox="405 1523 1345 1697"> <thead> <tr> <th>Item No.</th> <th>$\text{ØD} \pm 0.05$ [mm]</th> <th>$G \pm 0.03$ [mm]</th> <th>Colour</th> <th>Hardness ± 2</th> </tr> </thead> <tbody> <tr> <td>1</td> <td>8.20</td> <td>1.45</td> <td>natural</td> <td>20°Sh</td> </tr> <tr> <td>2</td> <td>8.20</td> <td>1.40</td> <td>natural</td> <td>40°Sh</td> </tr> </tbody> </table>	Item No.	$\text{ØD} \pm 0.05$ [mm]	$G \pm 0.03$ [mm]	Colour	Hardness ± 2	1	8.20	1.45	natural	20°Sh	2	8.20	1.40	natural	40°Sh
Item No.	$\text{ØD} \pm 0.05$ [mm]	$G \pm 0.03$ [mm]	Colour	Hardness ± 2												
1	8.20	1.45	natural	20°Sh												
2	8.20	1.40	natural	40°Sh												
URS/3	Number of moulded details received from one cycle – min. 4 pcs.															
URS/4	Moulded parts releasing with a pushing plate.															
URS/5	Manufacturer is obliged to provide its documentation together with the mould, in digital form (m.in. current drawings of 2D and 3D forming parts).															
URS/6	Mould should be delivered within 12 weeks from the payment of 50% of the order value.															

Attachment No. 5 to the Request for Quotation

Essential Terms of the Contract
(to Request for Quotation No. 02/KPO/2025)

CONDITIONS FOR CONTRACT MODIFICATION

1. Significant modifications to the provisions of the concluded contract may be made only in the following cases:
 - a. when the necessity for modification arises from circumstances that the Ordering Party, acting with due diligence, could not have foreseen;
 - b. in the event of an unforeseen force majeure occurrence preventing the execution of the Contract in accordance with its terms;
 - c. changes in generally applicable legal regulations affecting the execution of the contract.

Any amendments and supplements to the contract concluded with the selected Contractor must be made in the form of written annexes to the contract signed by both parties, under penalty of nullity.

Other Essential Contract Terms (not specified in the Request for Quotation):

Payment Conditions:

- 30% - upon signing the contract
- 30% - after FAT (Factory Acceptance Test) approval
- 40% - after SAT (Site Acceptance Test) approval, no later than 30 days after acceptance

Contractual Penalties:

The Seller shall pay the Buyer a contractual penalty for delay in the delivery of the Subject of Sale in the amount of 0.2% of the net price for each completed week of delay, but not more than 2% of that price.